



White Sound  
shh...shh  
not bleep...bleep

The bbs-tek® reversing alarms use multifrequency white sound, AKA broadband sound instead of the traditional single frequency sound of a conventional tonal alarm. The sound dissipates much quicker, is directional and is localised in the danger zone, resulting in an enormous reduction in noise nuisance and complaints.

Operators involved in all types of physical movement from conventional road transport including trucks and RCV's, buses and low-loaders to off-road applications including quarry vehicles, forklifts, earthmoving equipment and agricultural vehicles, are already experiencing the unique benefits of the bbs-tek® reversing alarm system.

Not only are noise nuisance and complaints considerably reduced, but the unique localisation feature of the bbs-tek® reversing alarm means that in busy environments you can tell instantly where the sound is coming from and, therefore, which vehicle is reversing.

This makes the bbs-tek® reversing alarms much safer when used in areas that have several vehicles moving.

- **Eliminates noise nuisance and complaints.**

White sound is easy on the ear and dissipates at twice the rate of conventional alarms, creating a better work site and less environmental disturbance.

- **Locatable.**

With bbs-tek® reversing alarms it is much easier to tell which vehicle is reversing toward you within a noisy environment.

- **Directional.**

The sound is concentrated within the danger zone, increasing people's response to the alarm and diminishing the chance of it being ignored.

## Sounder Units

Not all reversing alarms are built the same. Each model in the Brigade range uses a different type of sounder unit appropriate for its application.

### Driver

Ideal option for high sound pressure level (SPL) models. The Driver sounder unit incorporates a large magnet and voice coil for superior output. Brigade Driver models are tough, durable and fully waterproof (IP68), so units can be steam-cleaned and pressure washed. Excellent sound quality.

### Conventional Cone Speaker

A good option for medium and low SPL models, subject to design and materials used. *Not suitable for high SPL models over 102 dB(A) due to cone speaker over stress.* Brigade's cone speakers are tough, durable and fully waterproof (IP68), so can be steam-cleaned, pressure washed and offer long life in extreme conditions. Great sound quality, even under extremes of temperature and other adverse conditions.

## Lifetime Warranty



bbs-tek® reversing alarms are so robust they have a lifetime warranty that covers the alarm for the life of the vehicle.



## White Sound Reversing Alarms

bbs-tek Self-Adjusting

8

bbs-tek Fixed Volume

10

# White Sound Reversing Alarms

bbs-tek Self-Adjusting



BBS107SA



- Unique multi-frequency white sound.
- Continuously self-adjusts to 5-10dB above ambient sound pressure levels.
- Eliminates noise nuisance complaints.
- Sound confined to the danger zone.
- Instantly locatable sound.
- Environmentally sealed - IP68.
- Epoxy filled for maximum vibration resistance.
- Can be steam & pressure cleaned.
- Multi-voltage.
- Lifetime warranty.

|                                |                                    |                         |
|--------------------------------|------------------------------------|-------------------------|
| <b>Body :</b>                  | Medium Duty                        | AES                     |
|                                | Heavy Duty                         | Glass Reinforced Nylon  |
| <b>Cable Length :</b>          |                                    | 1m                      |
| <b>Vibration :</b>             |                                    | 10G                     |
| <b>EMC :</b>                   |                                    | CE, C-Tick & 'e' marked |
| <b>Standards :</b>             | Conforms to SAE J994 environmental |                         |
| <b>Operating Temperature :</b> | -40°C to 85°C                      |                         |
| <b>Ingress Protection :</b>    | IP68                               |                         |



Microphone for measuring ambient SPL



Microphone for measuring ambient SPL

## bbs-tek® Self-Adjusting

Take the guess work out of choosing the best sound pressure level (SPL) for your application.

Ideal for vehicles or machinery working in areas with widely differing ambient noise levels, where a fixed-volume reversing alarm will be either too quiet in loud environments (very hazardous), or too noisy in quiet environments (irritating and a nuisance).

Brigade bbs-tek® self-adjusting reversing alarms utilise a small hidden and highly robust microphone to measure ambient SPL. They then self-adjust their own SPL, up or down, to maintain an output of just 5-10dB louder than the surrounding environment.

Loud enough to be heard, but not so loud as to cause a nuisance.

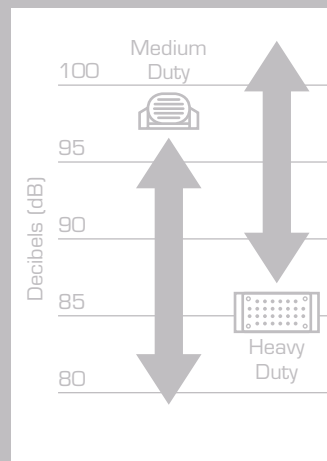

# White Sound Reversing Alarms

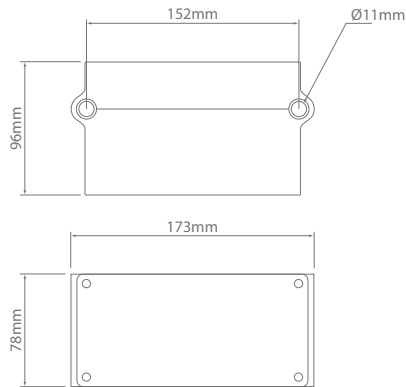

## bbs-tek Self-Adjusting - Heavy Duty

| Part No.        | Voltage | SPL - dB(A) @ 1m | Frequency - kHz | Current Draw (A) | Sounder Unit |
|-----------------|---------|------------------|-----------------|------------------|--------------|
| <b>BBS107SA</b> | 12-24   | 87 - 107         | Multi           | 1.0              | Driver       |

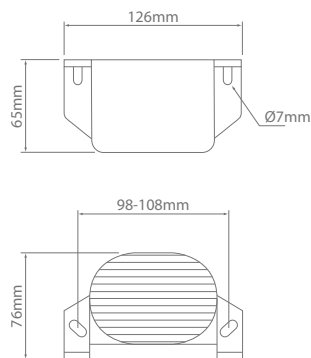

## bbs-tek Self-Adjusting - Medium Duty

| Part No.                            | Voltage | SPL - dB(A) @ 1m | Frequency - kHz | Current Draw (A) | Sounder Unit |
|-------------------------------------|---------|------------------|-----------------|------------------|--------------|
| <b>BBS97SA</b>                      | 12-24   | 77 - 97          | Multi           | 1.0              | Speaker      |
| <b>BBS97SAHV</b> <small>NEW</small> | 36-80   | 77 - 97          | Multi           | 0.15             | Speaker      |



# White Sound Reversing Alarms

bbs-tek Fixed Volume



BBS92HV



- Unique multi-frequency white sound.
- Eliminates noise nuisance complaints.
- Sound confined to the danger zone.
- Instantly locatable sound.
- Environmentally sealed - IP68.
- Epoxy filled for maximum vibration resistance.
- Can be steam & pressure cleaned.
- Multi-voltage.
- Lifetime warranty.

|                                |                                    |                         |
|--------------------------------|------------------------------------|-------------------------|
| <b>Body :</b>                  | Medium Duty                        | AES                     |
|                                | Heavy Duty                         | Glass Reinforced Nylon  |
| <b>Cable Length :</b>          |                                    | 1m                      |
| <b>Vibration :</b>             |                                    | 10G                     |
| <b>EMC :</b>                   |                                    | CE, C-Tick & 'e' marked |
| <b>Standards :</b>             | Conforms to SAE J994 environmental |                         |
| <b>Operating Temperature :</b> | -40°C to 85°C                      |                         |
| <b>Ingress Protection :</b>    | IP68                               |                         |

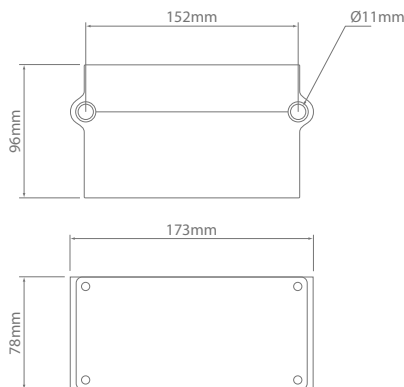

## bbs-tek® White Sound shh...shh not bleep...bleep

The bbs-tek® constant tone speaker uses multi-frequency white sound instead of the traditional single frequency sound. White Sound dissipates much quicker, is directional, and is localised in the danger zone, resulting in an enormous reduction in noise nuisance and complaints.

The unique localisation feature of the bbs-tek® White Sound means that in busy environments you can tell instantly where the sound is coming from and, therefore, the direction of possible danger.

This makes bbs-tek® White Sound® much safer when used in areas that have several vehicles moving.

### bbs-tek Fixed Volume - Heavy Duty

| Part No. | Voltage | SPL - dB(A) @ 1m | Frequency - kHz | Current Draw (A) | Sounder Unit |
|----------|---------|------------------|-----------------|------------------|--------------|
| BBS102   | 12-24   | 102              | Multi           | 1.0              | Driver       |
| BBS107   | 12-24   | 107              | Multi           | 1.0              | Driver       |

# White Sound Reversing Alarms



Fig 1

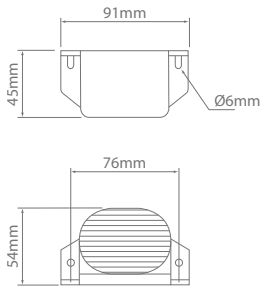

Fig 2

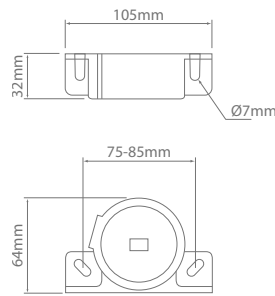
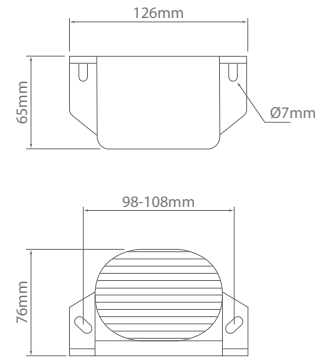
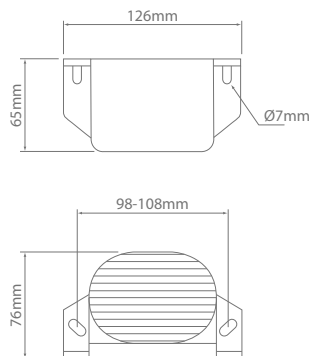

Fig 3



## bbs-tek Fixed Volume - Medium Duty

| Part No.  | Voltage | SPL - dB(A) @ 1m | Frequency - kHz | Current Draw (A) | Sounder Unit | Fig |
|---|---------|------------------|-----------------|------------------|--------------|-----|
| <b>BBS77</b>                                      | 12-24   | 77               | Multi           | 1.0              | Speaker      | 1   |
| <b>BBS82</b>                                      | 12-24   | 82               | Multi           | 0.2              | Speaker      | 2   |
| <b>BBS87</b>                                      | 12-24   | 87               | Multi           | 0.2              | Speaker      | 2   |
| <b>BBS92</b>                                      | 12-24   | 92               | Multi           | 0.2              | Speaker      | 2   |
| <b>BBS97</b>                                      | 12-24   | 97               | Multi           | 0.2              | Speaker      | 2   |
| <b>BBS82HV</b>                                    | 36-80   | 82               | Multi           | 0.15             | Speaker      | 3   |
| <b>BBS87HV</b>                                    | 36-80   | 87               | Multi           | 0.15             | Speaker      | 3   |
| <b>BBS92HV</b> <span style="color:red">NEW</span> | 36-80   | 92               | Multi           | 0.15             | Speaker      | 3   |
| <b>BBS97HV</b> <span style="color:red">NEW</span> | 36-80   | 97               | Multi           | 0.15             | Speaker      | 3   |



Armoured conduit sealed into housing

## NEW bbs-tek Fixed Volume - Medium Duty - Tanker Specification

| Part No.        | Voltage | SPL - dB(A) @ 1m | Frequency - kHz | Current Draw (A) | Sounder Unit |
|-----------------|---------|------------------|-----------------|------------------|--------------|
| <b>BBS92ADR</b> | 12-24   | 92               | Multi           | 0.3              | Speaker      |

Tanker specification features 460mm cable with armoured conduit.

